

BARE CONCRETE OVAL VESSEL BASIN 800 X 425 X 144 NTH

ELEMENTI

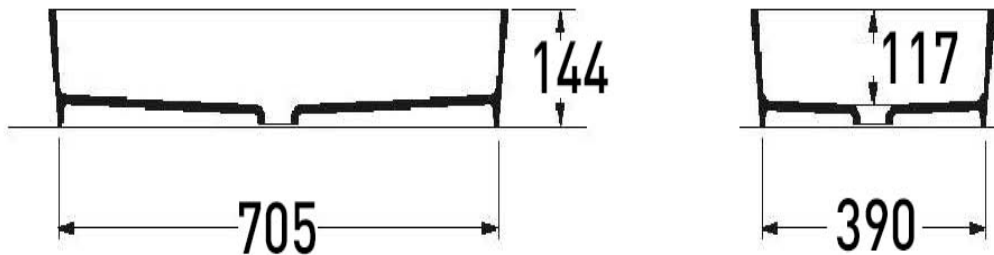
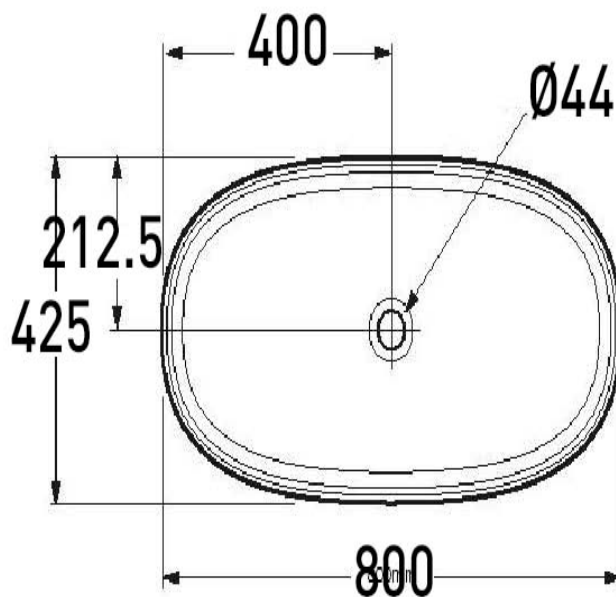

Residential/Light Commercial Use

Suitable for Residential/Light Commercial Use (Kitchens, Bathrooms and Laundries in Hotels, Motels and Retirement Villages).

5

Guarantee

5 Year Guarantee (Hotel and public spaces warranty is 2 years only. Discolouration and natural pitting is excluded from warranty)



Hand Finished

Each piece is hand crafted & unique



Glass Fibre Reinforced

Glass Fibre Reinforced concrete give much higher flexural and tensile strengths than normal concrete.



Heat + Stain resistant sealer

All concrete products are sealed with heat and stain resistant sealer which is also highly scratch resistant.





Made in New
Zealand

Designed & Engineered in New Zealand

BARE Concrete Basins combine warm pastel colours with the natural harsh elements of concrete to create a focal point in any bathroom. Each piece is handcrafted and distinctively designed to embrace the natural properties of concrete. The soft oval basin shape brings a gentle ambience to the environment whilst showcasing the raw properties of the material.