

Eclipse Basin Mixer
Mirrored Black
VECL20MB

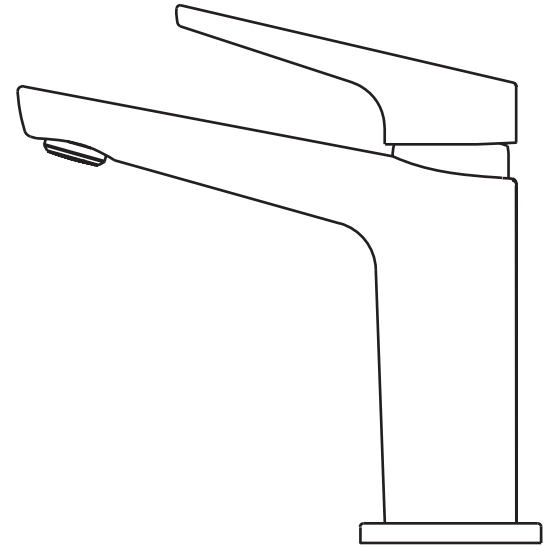

Congratulations on your purchase of this high quality product from Voda Plumbingware.
Please read the following before installation and retain (along with your receipt) for future reference.

TECHNICAL SPECIFICATIONS

Suitable for All Pressures

Minimum Pressure = 35kPa

Maximum operating Pressure = 500kPa

Maximum operating Temperature = 65 deg. Celsius

For domestic use only.

CONFIGURATION

Mains Pressure systems Remove the flow restrictor from the nut of the cold hose and change aerator to the Mains Pressure one (supplied).

Unequal Low systems Install as supplied.

Equal Low systems Prior to installation, remove the flow restrictor from the nut of the cold hose.

INSTALLATION

For pressures exceeding 500kPa, install a pressure limiting valve. Failure to do so may void the warranty.

- Before commencing installation turn off the water supply.
- Position tap in 35mm hole, making sure the seal between tap and supporting surface is in place.
- Anchor to bench with fittings pack.
- Thoroughly flush all pipes to eliminate any remaining dirt and residue and install inline filters.
- Connect supply hoses to plumbing connections. **Minimum bend for flexible hose is 35mm radius.**
- **Do not stretch, crush or twist hoses. Do not swage hose ends.**
- Turn on mains supply.
- Check for leaks.

Plumbers Note: Do not pressure test this mixer under static pressure.

ATTACH PROOF OF PURCHASE HERE

WARRANTY

Please refer to our website for warranty information: www.vodaplumbingware.co.nz/warranty

In the unlikely event that this product fails during its warranty period, phone our Customer Service team immediately on 0508 367 366 – as unauthorised removal of the product may void the warranty.

CARE AND MAINTENANCE

When cleaning this product (including chrome, stainless steel, coloured or any other surface coating) you must not use any type of astringent, abrasive or citric cleaners.

We recommend using only a soft, damp cloth and on occasion a mild soap solution. Try to avoid excessive scrubbing as this could cause damage and void your warranty.