



GENERAL INFO

DESIGNED FOR MAINS WATER

Sparkling, Chilled & Ambient Water on Tap

The SPARQ S5 domestic system gives you the luxury of filtered sparkling or still water, right in the heart of your home or office. A simple touch on the stylish LED panel will give you filtered sparkling or still water, chilled to perfection. The SPARQ S5 is an object of prestige. With sleek lines, elegant styling and the luxury of sparkling water on tap, it is the perfect finishing touch to your kitchen or entertaining area.

FEATURES & BENEFITS

- A choice of sparkling, chilled & filtered water, straight from the tap.
- Soft touch buttons on the stylish LED panel.
- Compact under sink system.
- Sediment, dirt and other particles filtered down to 0.1 micron* including Giardia and Cryptosporidium cysts.
- DIY quick-twist cartridge change.
- Using Ultra Z Filtration Technology, the Z1-R cartridge has the ability to protect against cysts and bacteria such as E. coli. Reduces Trihalomethane (THM's).
- Provides pure, safe, filtered water, free of chlorine.
- The SPARQ S5 includes a built in cooling system that chills the water down to 2°C for a refreshingly cold drink.
- WaterMark approved.



SPARQ-S5-CH

Chilled, Sparkling & Ambient Unit with Chrome Tap



SPARQ-S5-BK

Chilled, Sparkling & Ambient Unit with Matt Black Tap

TECHNICAL DATA

Ordering Code	SPARQ-S5-CH	SPARQ-S5-BK
Replacement Filter Cartridge:	Z1-R	
Filtration:	Ultra Z Technology, 0.1* micron	
Filter Capacity:	23,000 L	
Replacement CO ₂ Canister:	SPARQ-CO2 (single) / SPARQ-CO2-2 (twin pack)	
Chilled Water Flow:	100 glasses/hour [~]	
Min/Max Pressure:	138 - 500 [~] kPa	
Min/Max Air Temperature:	2°C - 50°C (protect from freezing)	
Chilled Temperature:	2°C - 10°C	
Power Requirements:	220-240 V / 50 Hz	
Maximum Power Consumption:	100 W	
Tap Colour:	Chrome	Matt Black
Tap Dimensions:	345 (h) x 197 (w) mm	350 (h) x 197 (w) mm
Appliance Dimensions:	390 (h) x 230 (w) x 370 (d) mm	
Filter Dimensions:	290 (h) x 93 (w) x 110 (d) mm	
Weight:	18 kg	
Water Connection:	1/2" BSP (1/4" tube)	
Water Supply:	Mains/Towns Water Supply Only	
Required Hole For Tap:	26 mm	
Warranty:	2 years [^]	

*Micron rating is nominal. [~]Glass size is based on 200ml. [~]Where line pressure exceeds 500 kPa, an approved pressure limiting device must be installed to comply with Australian & New Zealand Plumbing Standards. (Ref. AS/NZS 3500.1:2021, Clause 3.3.4). [^]2 year warranty is 1 year parts and labour plus 1 year parts only. Excludes consumables. Use only genuine Puretec cartridges and replacements.

FILTRATION TECHNOLOGY

The Sparq S5 system uses Ultra Z Filtration Technology to reduce unwelcome elements in your water. With 3 levels of filtration, the cartridge filters out sediment down to 0.1 micron* as well as filtering out bad taste, odour, chlorine and protects against cysts and bacteria such as E. coli. Leaving you with healthy, great tasting, clean, safe and pure water.

Chilling the water

The SPARQ S5 includes a built in cooling system that chills the water down to 2°C for a refreshingly cold drink. You can choose between ambient or chilled when dispensing still water. The sparkling water is delivered chilled only.

Carbonation system

Once the water has been purified, it can be delivered either sparkling or still. If sparkling water is selected, the system injects CO₂ gas into the water stream as it is dispensed. This gives you chilled, fresh water with just the right amount of sparkle. The CO₂ canister is easy to replace, and usually lasts between 9 to 12 months, depending on individual use.

Stage 1

- Removes particles.
- Clarifies the water.
- Removes sediment, rust, sand, silt & algae.

Stage 2

- Chlorine and chloramine reduction.
- Eliminates bad taste and odours.
- Chemical pesticides & sulphur reduction.

Stage 3

- Ultra Z Filtration membrane finely filters to 0.1 micron*.
- Provides protection against cysts and bacteria, such as E. coli.
- Removes the finest particles.

DIAGRAM & FILTRATION TECHNOLOGY

The SPARQ S5 is surprisingly cost effective, which means it's a luxury you can afford.

Choice of tap colours, classic chrome or a modern matt black finish.



Reduce the number of plastic water bottles you throw away. With the Sparq S5, you can fill up your own reusable bottle with fresh, filtered sparkling or still water, anytime.

With sparkling water available on demand, you can spice up your daily water drinking habits. No more sugary soft drinks, just fresh clean water that you can drink all day.

Stylish and modern tap with a simple touch LED panel enables you to choose from chilled, sparkling or ambient filtered water.

The do-it-yourself, valve-in-filter head makes replacing cartridges quick, easy and with less mess. Mounting is simple too, and can be installed horizontally or vertically.

Includes a pressure limiting valve to ensure your system and tap is protected from extreme pressures and water hammer, ensuring good consistent pressure and reduces noise.

Includes a built in cooling system that chills the water for a refreshingly cold drink.



Features Ultra Z Filtration Technology, a three stage process to filter down sediment to 0.1 micron* as well as filtering out bad taste, odour, chlorine and protects against cysts and bacteria such as E. coli.

Shut off valve makes maintenance even easier to perform (1/4" tube x 1/2" BSPM x 1/2" BSPF)

The unit can be installed wherever there is mains water access. Using a qualified plumber to perform the initial installation, who should have the unit installed and ready to use in less than 90 minutes.

The compact and stylish under sink system has been designed to fit beneath most kitchen benches, saving you precious countertop space. The rear panel with clearly labeled connections makes installation a breeze.

Easy-to-change disposable CO2 gas cylinder. Produces Approx. 200 - 350 litres of sparkling water or around 3 - 9 months per CO2 bottle, depending on individual use.

Note: All cold water lines are 1/4" tube.
*Micron rating is nominal.



VENTILATION REQUIREMENTS

Ventilation

Ventilation Requirements

WARNING! Allow at least 50 mm clearance on either side of the unit, 150 mm at the rear and 200 mm above the main unit.

Sufficient air circulation **MUST** be provided in order for the system to operate and function correctly. Allow enough space for the system to be easily accessed for any servicing needs.

Fit the upper cabinet rail (where the cabinet door rests) with 3 mm silicon door buffers. This will allow for the warm air to be expelled from the cabinet.

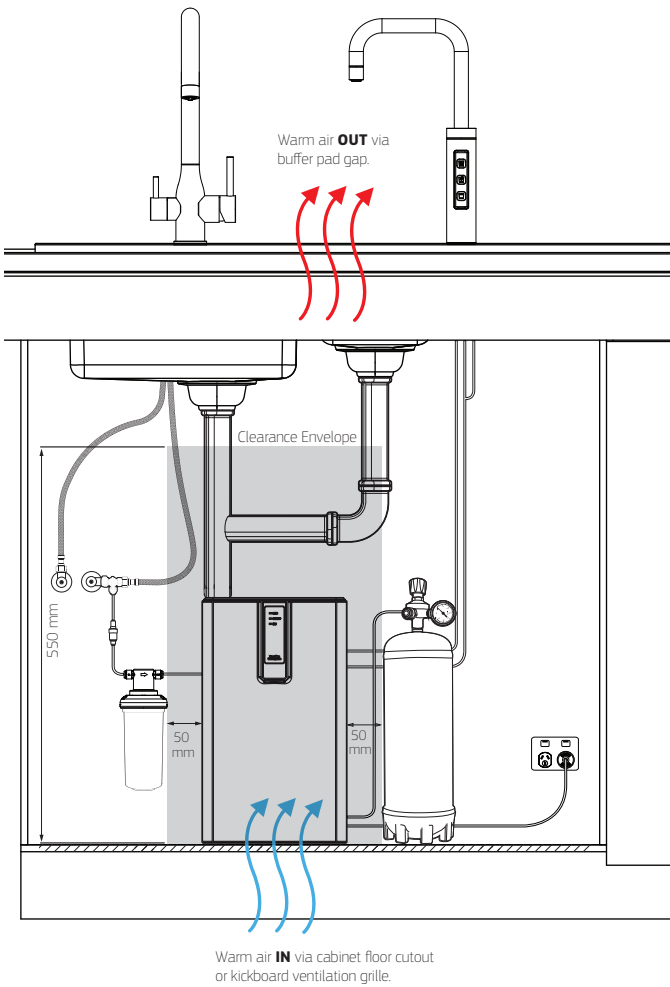

NOTE: Clearance at the back of the unit from the wall needs to be 150 mm.

Cutouts

To allow the cool air to be drawn into the cabinet, cut out the cabinet floor (**A. Cabinet Floor cutout**). Ideally this should be as large as possible along the cabinet for maximum ventilation.

Alternatively, a ventilation kit (not included) can be installed by cutting out a hole for a kickboard ventilation grille (**B. Kickboard Ventilation Cutout**), a cutout on the cabinet floor (**C. Floor Cabinet Cutout**) and ducting to connect them. Follow the manufacturer's installation guide included with your kit.

Where cabinet temperatures are higher than 35°C, it is recommended an exhaust fan kit is fitted (not included) in place of the kickboard ventilation grille.

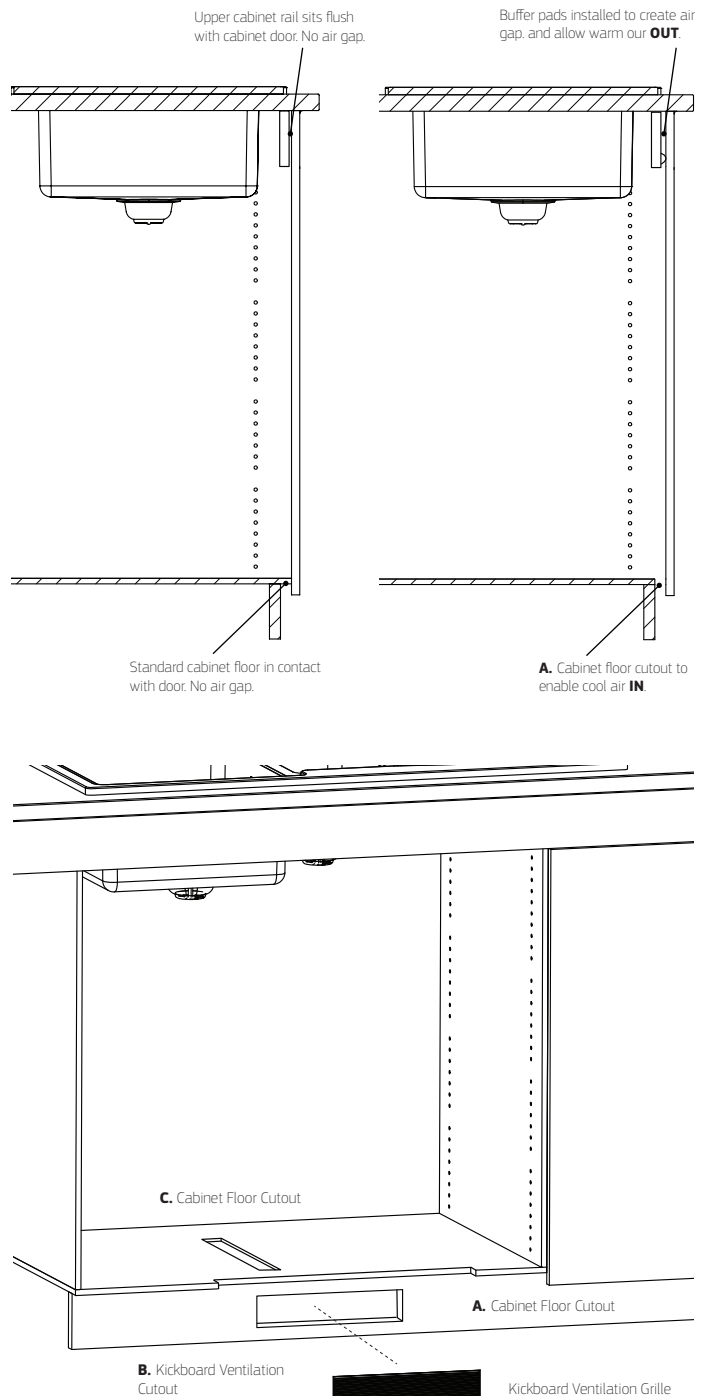

PRODUCT DIMENSIONS Measurements in Millimeters (mm)

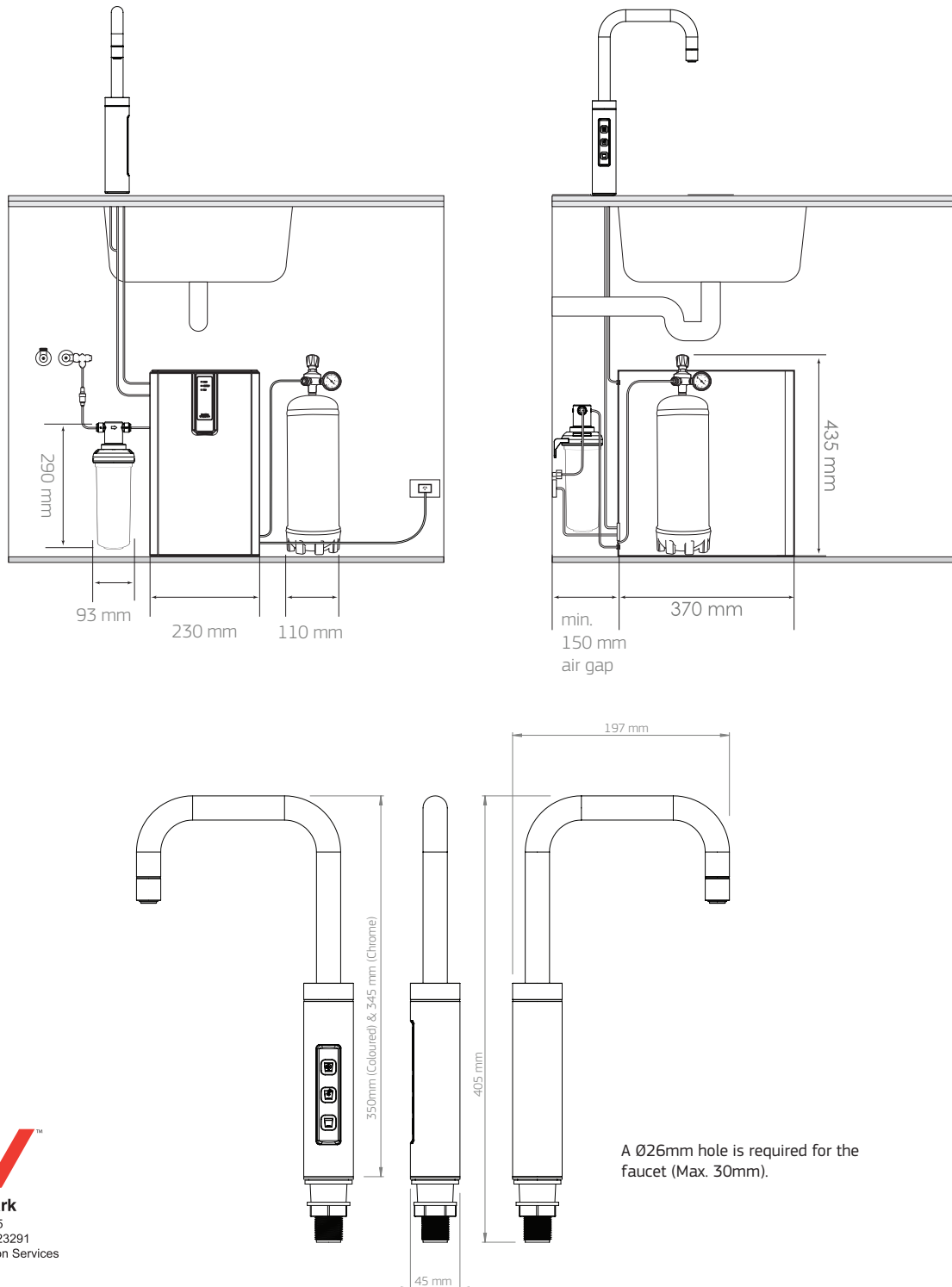

Note:

1. No claims can be made based on the specifications and images in this document. The design, technology, colours, features and prices are subject to change.
 2. This document and all its contents are copyright protected. All rights are reserved, particularly alteration, translation and reproduction using electronic systems.
 3. ^Warranties in this document cover parts and labour for the first year where applicable, subject to approval. Excludes consumables.
- Our Water Filtration Specialists can provide you with advice to suit your needs.