

INSTALLATION GUIDE

FELTON

AXISS RAIN SHOWER COLUMN BLACK AXRSCB

SYSTEM REQUIREMENTS

To ensure the optimum performance and customer satisfaction please adhere to the following:

- Flush out all pipe work prior to installation.
- Maximum hot water temperature is 60°C. If the water temperature exceeds 60°C an approved tempering valve must be fitted.
- Installation should comply with relevant local authority requirements.
- In accordance with good plumbing practice, filters should be fitted to supply lines to eliminate damage to the ceramic cartridge from suspended solids.
- AS/NZS 3500.1 states that pressures above 500kPa can cause damage from water hammer, reduce the life of appliances, taps & fittings, cause excessive noise in the system and recommend that a pressure limiting valve (PLV) be fitted.

MAXIMUM STATIC PRESSURE

Maximum static pressure 500kPa. If water pressure exceeds or is likely to exceed 500kPa, an approved pressure limiting valve must be fitted.

MINIMUM STATIC PRESSURE

Minimum static pressure 150kPa. To ensure optimal performance the static pressure must be greater or equal to 150kPa.



Failure to comply with the above will void warranties.

WHAT IS IN THE PACK



2 x Wall Anchors



2 x Screws

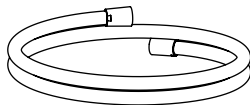

1 x Hose

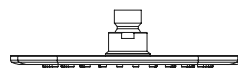

1 x Rain Head



2 x Flow Restrictor & Sleeve



Chrome Flange (Diverter Valve)



Bottom Chrome Flange



1 x Single Spray Handpiece

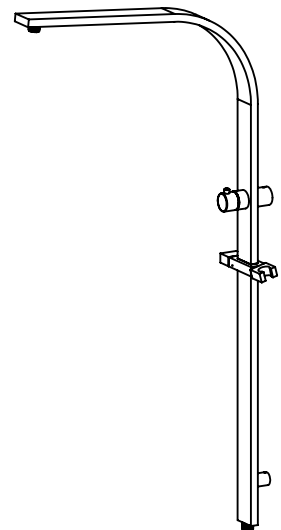

1 x Rail & Arm

HOW TO INSTALL

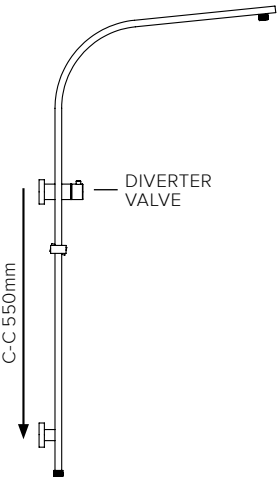
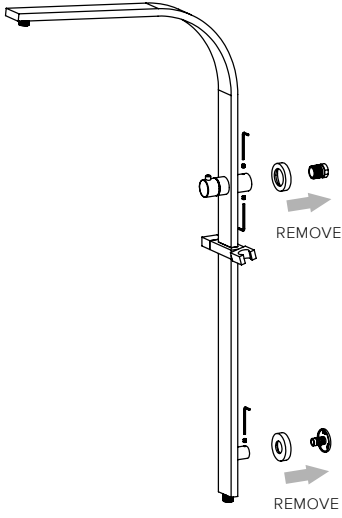
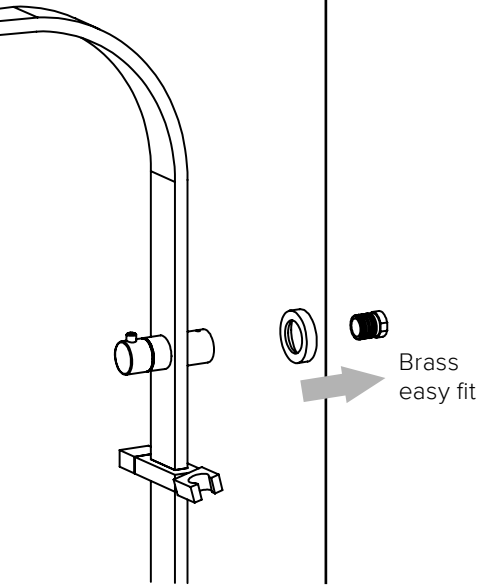
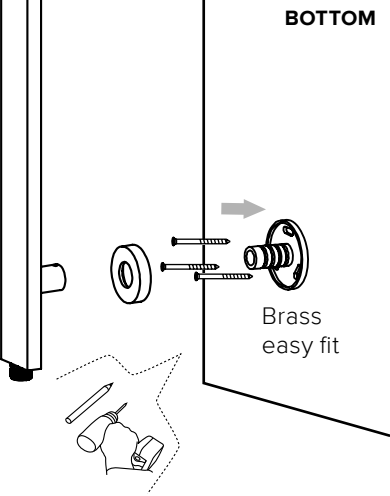
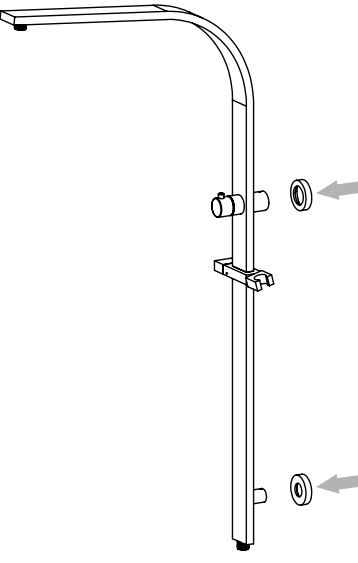
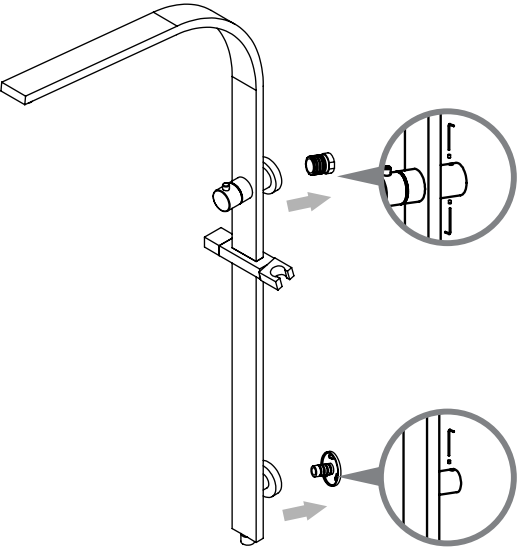
 <p>Mark down vertical of 550mm from centre of water outlet. Warning: Ensure no water pipe or power cable in wall at this location. IMPORTANT: The threaded water outlet must not protrude more than 10mm from wall face. Apply thread seal tape to water outlet.</p> <p>1.</p>	 <p>Loosen grub screws on body of diverter valve and lower mounting bracket and withdraw the brass easy fit.</p> <p>2.</p>	<p style="text-align: right;">TOP</p>  <p>Screw the top easy fit onto water outlet till it is flush against the wall face.</p> <p>3.</p>
<p style="text-align: right;">BOTTOM</p>  <p>Then mark and use screws to fasten bottom easy fit into place.</p> <p><i>(If installing into concrete, use toggles provided. Squeeze to close each toggle and push in until flush with the wall).</i></p> <p>3.</p>	 <p>Fit chrome flange onto top and bottom bracket.</p> <p>4.</p>	 <p>Fit the entire assembly onto wall by tightening the grub screws on the bottom and top mounting bracket.</p> <p>5.</p>

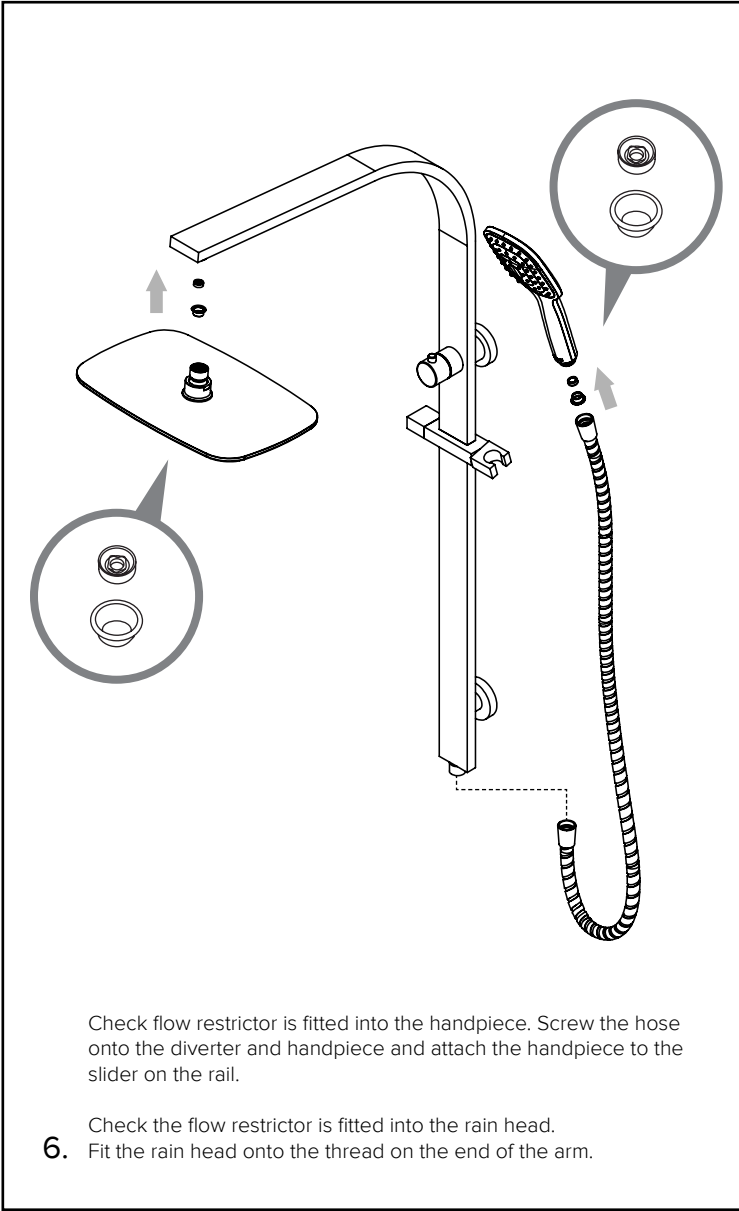

Warranty, Maintenance and Care YOUR COPY TO KEEP

Felton Industries Limited guarantees these mixers to be free from defects in materials and workmanship for a period of ten (10) years from the date of purchase. Fair wear and tear is expressly excluded. This warranty is effective for 10 years from the date of purchase for the supply of replacement parts (only) and five (5) years from the date of purchase for plumber's labour relating solely to repairing or replacing the mixer, provided the product is installed by a registered plumber. You must retain proof of purchase of the product (such as an invoice or receipt) and proof of installation by a registered plumber and provide these to Felton on request.

Where products are promoted as "5 Year Limited Warranty on Product Finish", Felton Industries Limited guarantees these product finishes to be free from defects in materials and workmanship under normal installation, use and service for a period of five (5) years from the date of purchase. Fair wear and tear is expressly excluded. This warranty is effective for five (5) years from the date of purchase and covers the product finish only. You must retain proof of purchase of the product (such as an invoice or receipt) and provide this to Felton on request. This warranty is for manufacturing defects only and does not cover any damage to product due to abuse, negligence or improper installation. This warranty is given on the understanding that the product is installed and operated according to Felton's installation guide and the Australian/New Zealand standard AS/NZS3500. This warranty is provided to persons who are a "consumer" under the Consumer Guarantees Act 1993 only and for use in domestic/residential dwellings only (not for commercial use).

 At no stage should any surface coatings be cleaned with cleaning agents that contain a corrosive acid or a scouring additive. Surface coatings should be cleaned with liquid detergent or soap and water. Any damage caused through the use of an unsuitable cleaner will not be covered by this warranty. This warranty is subject to any other rights or remedies that you may have under the Consumer Guarantees Act 1993 (or any other applicable legislation) and to Felton's Terms of Trade.

Please fill in the details below, attach your receipt to this installation guide and keep as your proof of purchase.

Purchased at:

Date of purchase:

Installed by:

For technical assistance please ring: 0800 743 358 or (09) 528 0810