

SP90D2WH/SP90D2WHM

SPLASH

900, 2 DRAWER

vcboc
FOR BATHROOMS



Splash Basin

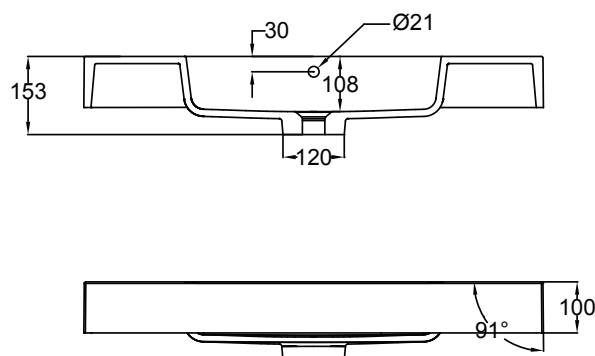
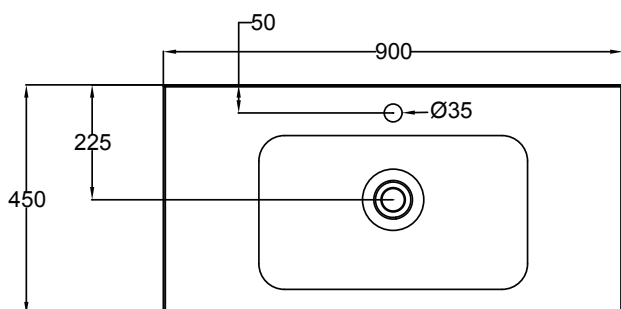

NB: Drawings indicate the technical measurements only and is not a reflection of how the unit will look.

SP90D2WH/SP90D2WHM SPLASH 900, 2 DRAWER

- Dimensions - W 900mm H 550mm D 450mm
- Polymarble top. Polymarble is a composite product and is very durable.
- Also available as a floor unit.
- Paint - The paint used on our products is polyurethane or UV based. It is five times harder and more durable than lacquer finishes. White only.
- TIMBER EFFECT (Melamine)- Our woodgrain melamine is a low pressure laminate. Two colours are available Charred Oak and Driftwood.

FINISHES



Driftwood



White



Charred Oak

SP90D2WH/SP90D2WHM

SPLASH

900, 2 DRAWER

vcboc
FOR BATHROOMS

Splash Cabinet

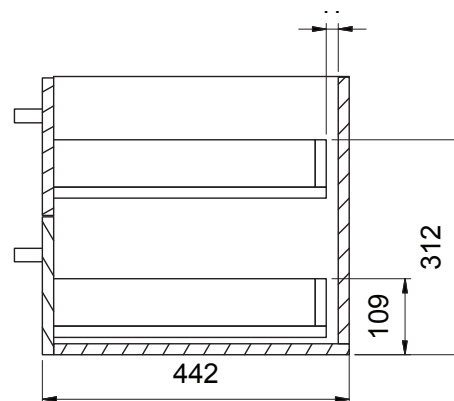
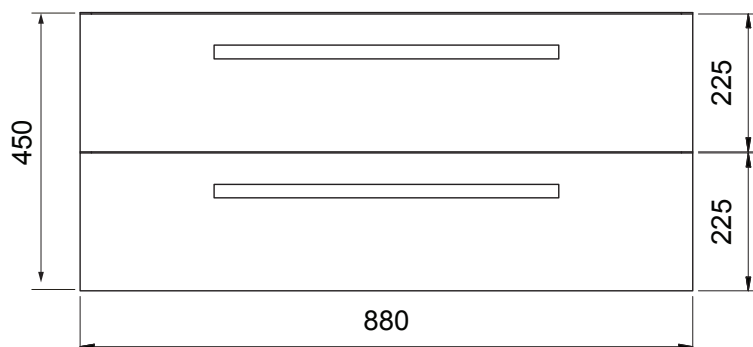

SPLASH Double Drawer (Top & Bottom) Side View

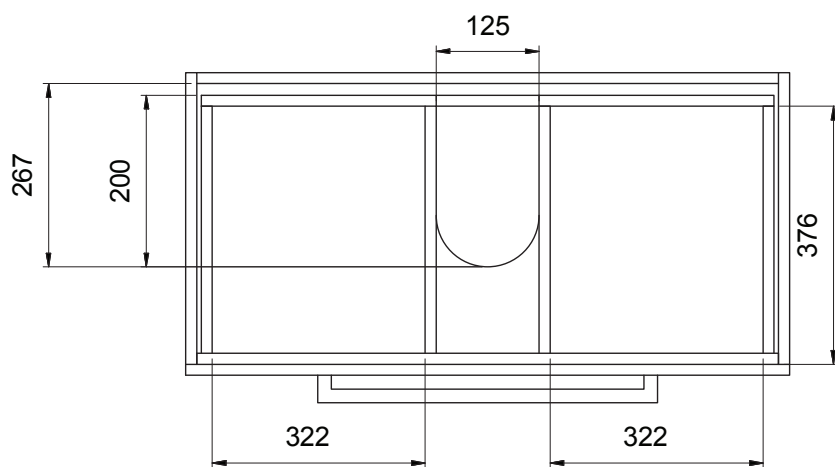

SP90D2WH Top View showing Drawers

NB: Drawings indicate the technical measurements only and is not a reflection of how the unit will look.