

## BUTLER SINK DOUBLE WITH 90MM STRAINER WASTE NTH

18822.10

ELEMENTI

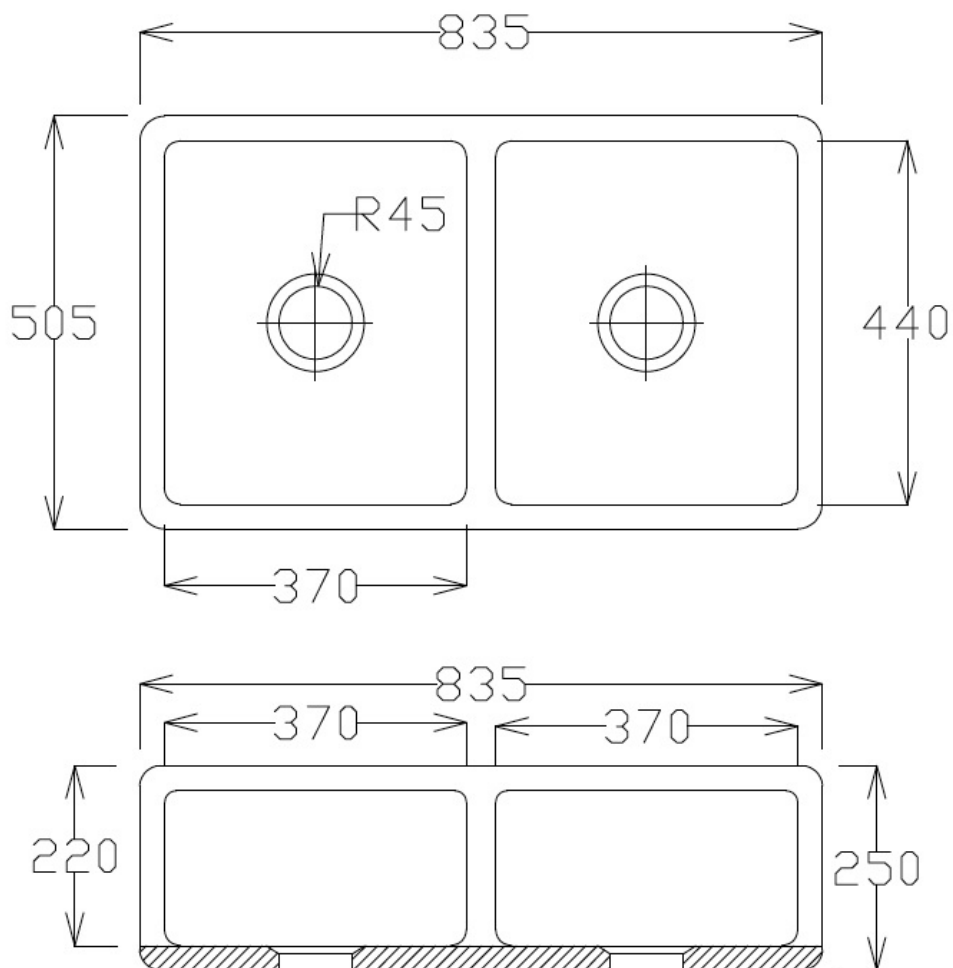

Residential/Light  
Commercial

Suitable for Residential/Light Commercial Use (Kitchens,  
Bathrooms and Laundries in Motels, Hotels and  
Retirement Villages)

5

Guarantee

5 Year Guarantee



VC Allowance

Please give an allowance of 10mm (-/+) for all Vitreous  
China basin dimensions.



Elementi Butler Sinks are individually handcrafted and finished in fireclay. Cool and silky to touch, they have a hard non-porous surface giving excellent resistance to all commonly used chemicals and detergents and are extremely resistant to heat. Inspired design and superb craftsmanship, the quality and durability of the classic fireclay ceramic Butler's sink are as dependable as ever. As practical now as it was a century ago.