

BUTLER SINK SINGLE WITH 90MM STRAINER WASTE NTH

18821.10

ELEMENTi

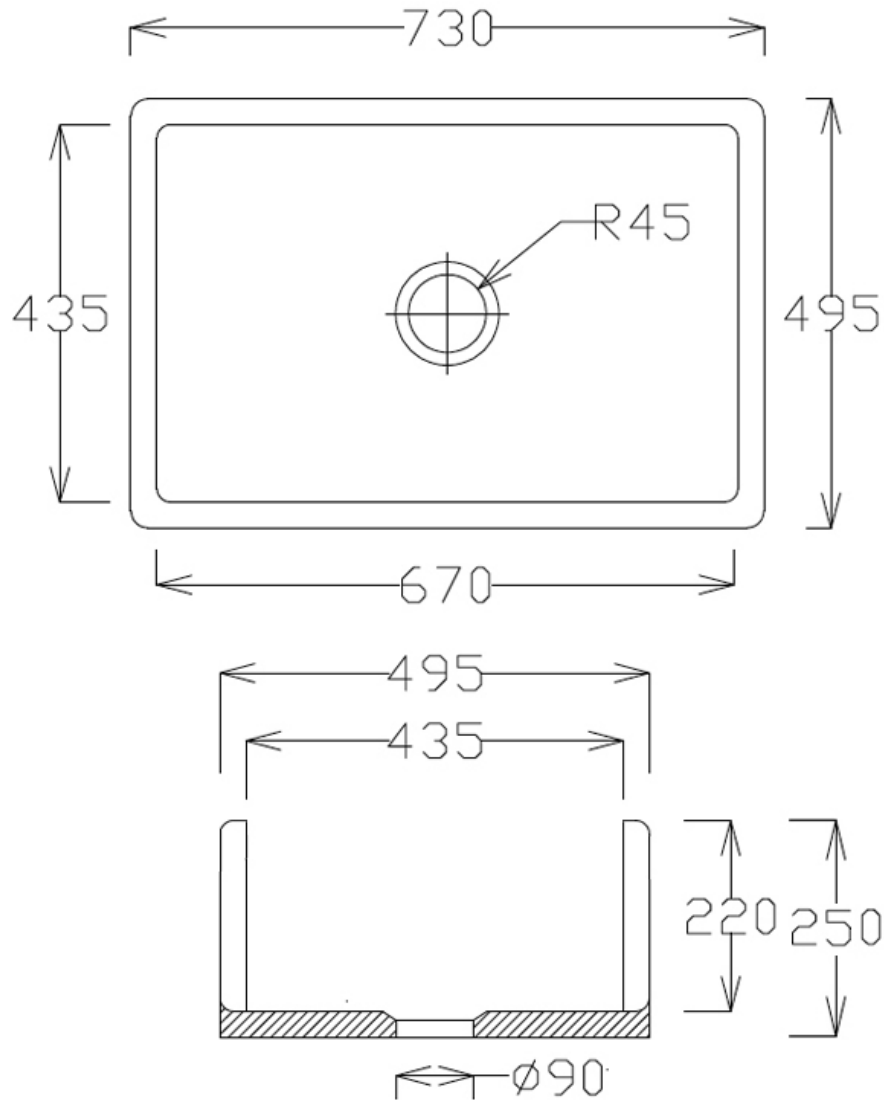

5

Guarantee

5 Year Guarantee



Residential/Light Commercial

Suitable for Residential/Light Commercial Use (Kitchens, Bathrooms and Laundries in Motels, Hotels and Retirement Villages)



Elementi Butler Sinks are individually handcrafted and finished in fireclay. Cool and silky to touch, they have a hard non-porous surface giving excellent resistance to all commonly used chemicals and detergents and are extremely resistant to heat. Inspired design and superb craftsmanship, the quality and durability of the classic fireclay ceramic Butler's sink are as dependable as ever. As practical now as it was a century ago.