

EVOLVE SHOWER SQUARE 900x900 2 SIDED BLACK - CENTRE  
WASTE TRAY MOULDED WALL

ELEMENTi

11958.13

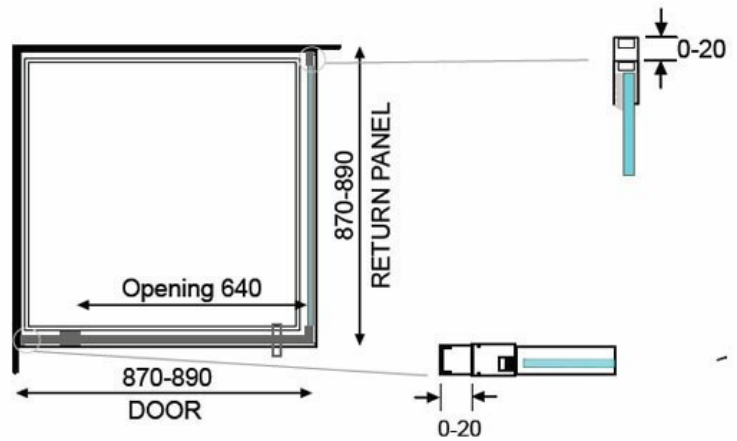
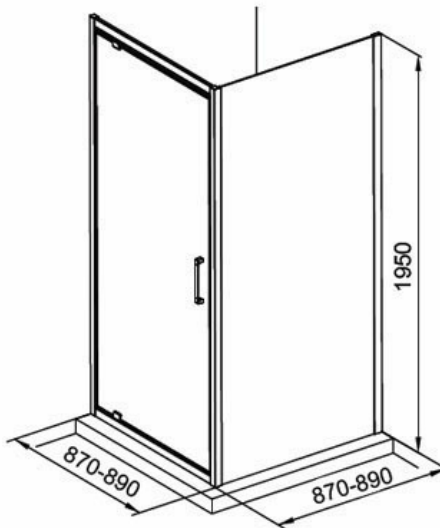
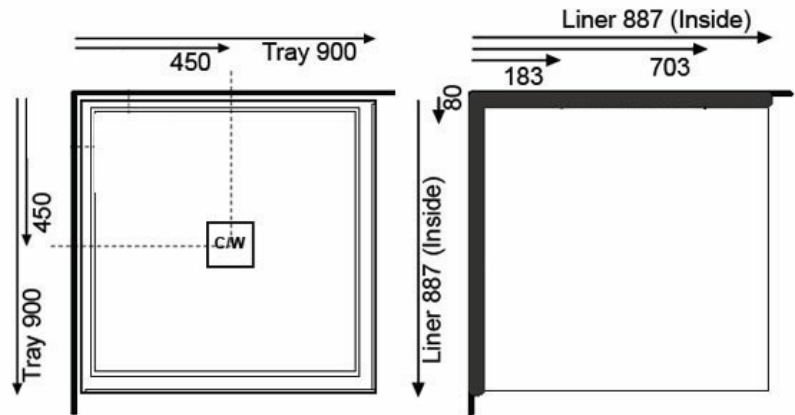
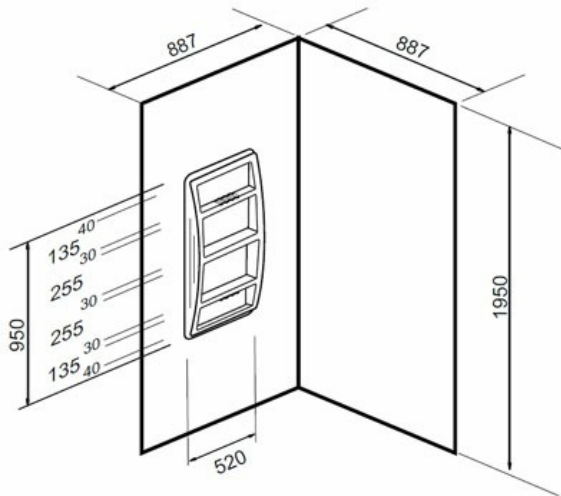

DOOR CAN BE INSTALLED  
EITHER LEFT OR RIGHT



Residential/Light  
Commercial Use

Suitable for Residential/Light Commercial Use (Kitchens, Bathrooms and Laundries in Hotels, Motels and Retirement Villages).

1

Guarantee

1 Year Guarantee on shower enclosure seals and drip strips

5

Guarantee

5 Year Guarantee on Black Finish

10

Guarantee

10 Year Guarantee\* Terms & Conditions apply



Safety Lip

A 5mm Safety Lip on the front edge of the tray, creates more surface to silicone preventing leakage from under the door or extrusion.





**Nano Technology**

NANO glass (ClearShield) has been specially developed by Ritec using advanced NANO technology creating a non stick surface. This award winning technology makes glass easier to clean and resists staining and discolouration.



**AS NZS 2208**

Safety Glass tested to AS NZS 2208 standard.



**Easy Clean**

Easy Clean Design. Removable rollers and door seals also allow for easy cleaning.



**Weight Tested**

Weight Tested to 200kg

Step into a new world of showering with the Evolve Overheight Enclosure. The European minimalist design of Evolve features our new smooth flat profile tray with integrated square waste and premium fittings to provide a luxurious shower experience.